

# Heat pumps create moisture. Send it to the drain.

When the fan in a heat pump water heater draws in air, the system collects not only heat but humidity. Each day, the heater can create 1-2 gallons of condensate.

## Best-case scenario

The easiest heat pump water heater installations pipe condensate to an existing floor drain or into an existing drain line. Several options are shown in the figures.

Option 1: Drain to local waste line

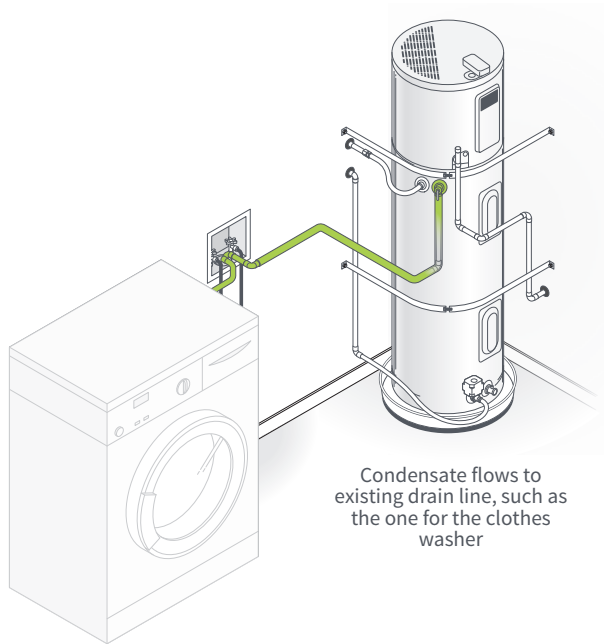

Option 2: Drain to floor

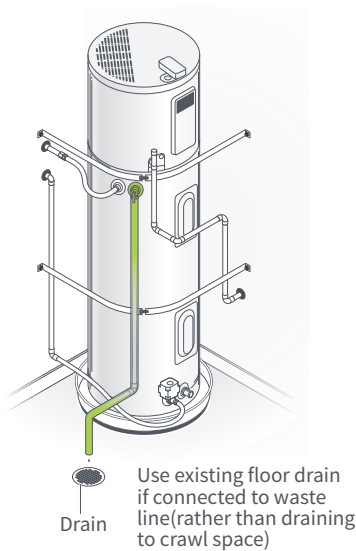

Option 3: Drain to landscaping outdoors (if local codes allow)

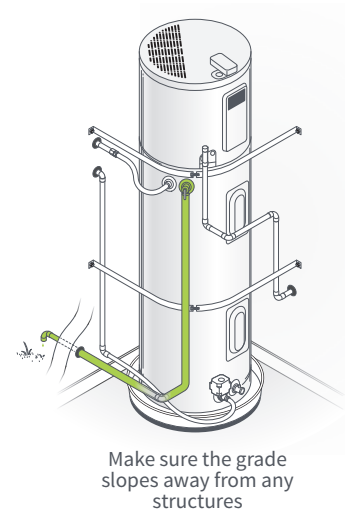

Option 4: If below ground level, drain to condensate pump

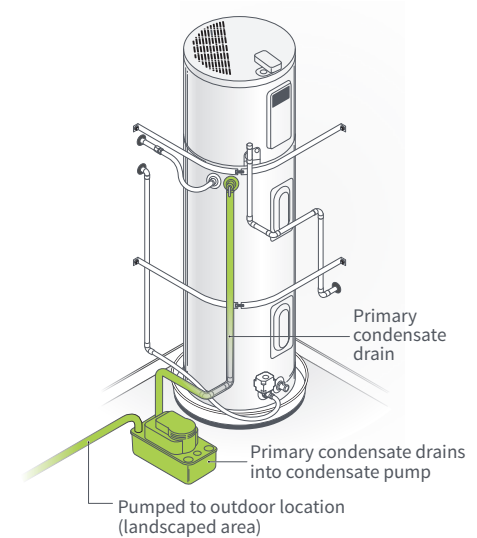

**Insulate the drain line.** When humid air comes in contact with cold pipes, the pipes begin to sweat, much like a glass of ice water on a summer day. Reduce the condensation by wrapping the pipes with insulation.